

CHOOSING YOUR DESIGN & LAYOUT

BRANCH AND TEE METHOD

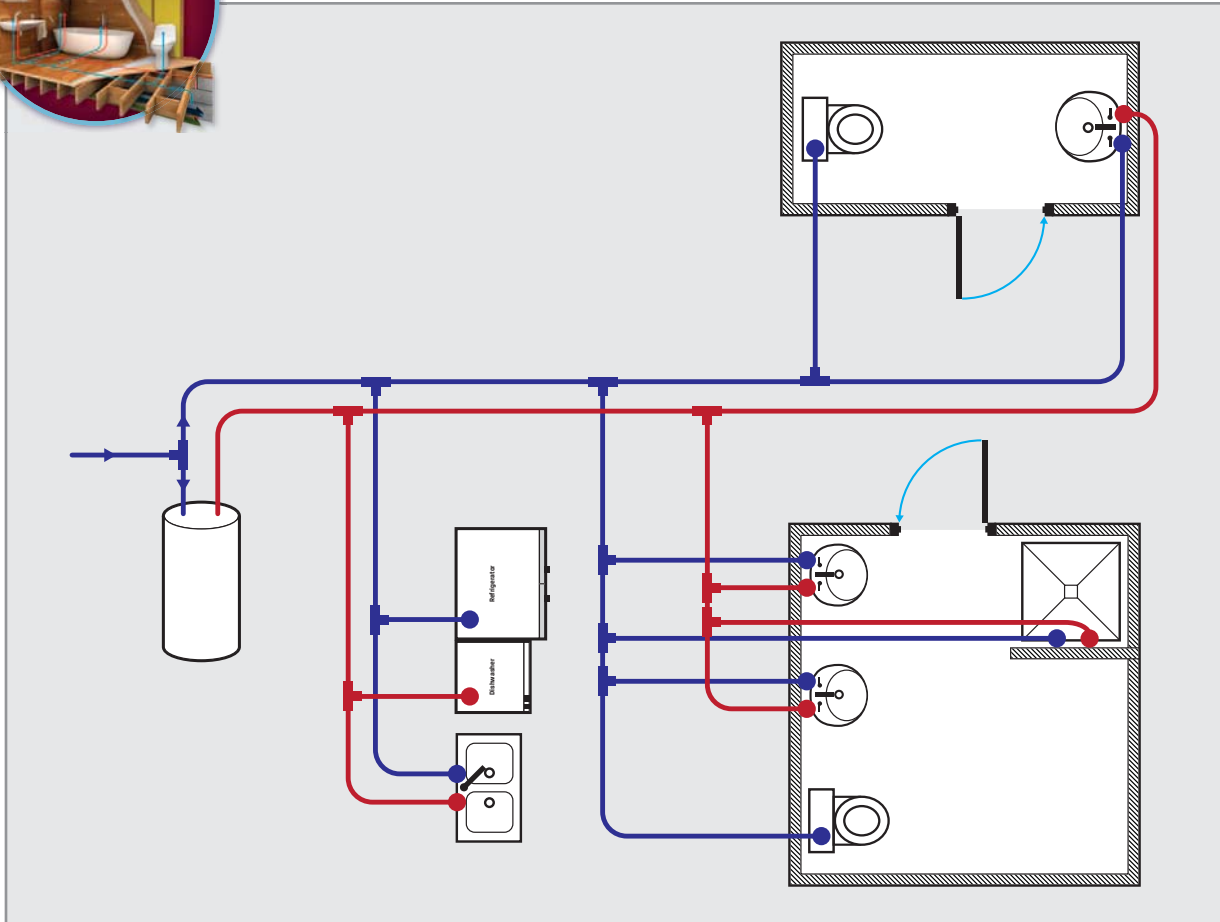

This system incorporates one set of main hot and cold lines with all the fixtures branching off of the main lines with flow through tee's until the last fixture is reduced off the end of the line.



Pros: Saves on tubing. No need to carry different multiport tee's or manifolds to job.

Cons: Pressures will vary downstream during the use of upstream fixtures. Hot water will take longer to get to furthest point.

HOME RUN METHOD



This type of install incorporates a dedicated line or a set of lines to every fixture from your water heater.

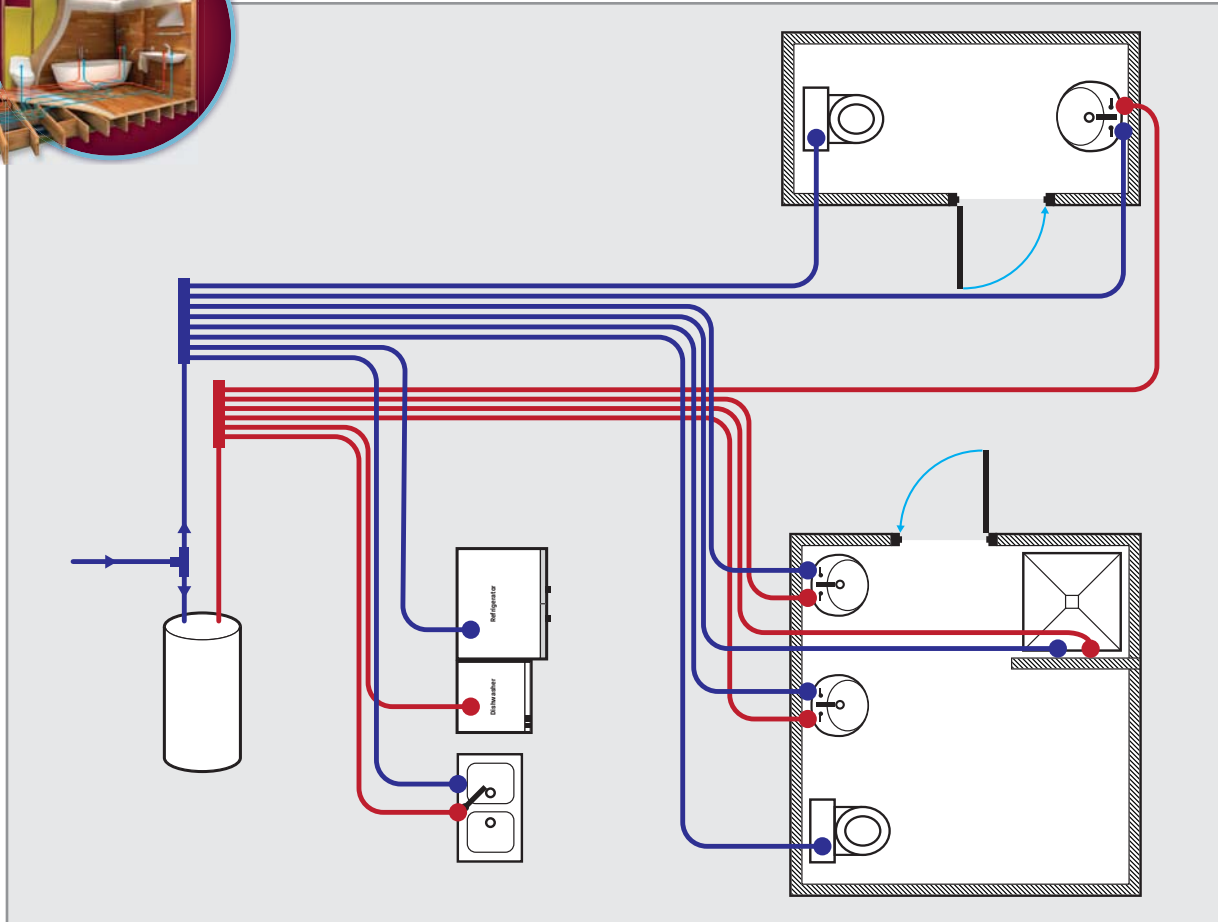

Pros: Less fittings are used. No need to carry many different fittings to the job. Pressures remain the same at all times. Large main lines are not needed to run throughout the building. If one line is ever compromised it is easy to isolate rather than shutting the whole system down.

Cons: More tubing is used than in any other application. A fair amount of space is needed for the manifold.

COMBINATION METHOD



This installation routes a set of main lines using multiport tee's serving a cluster of fixtures, such as a bathroom, kitchen, or laundry room.

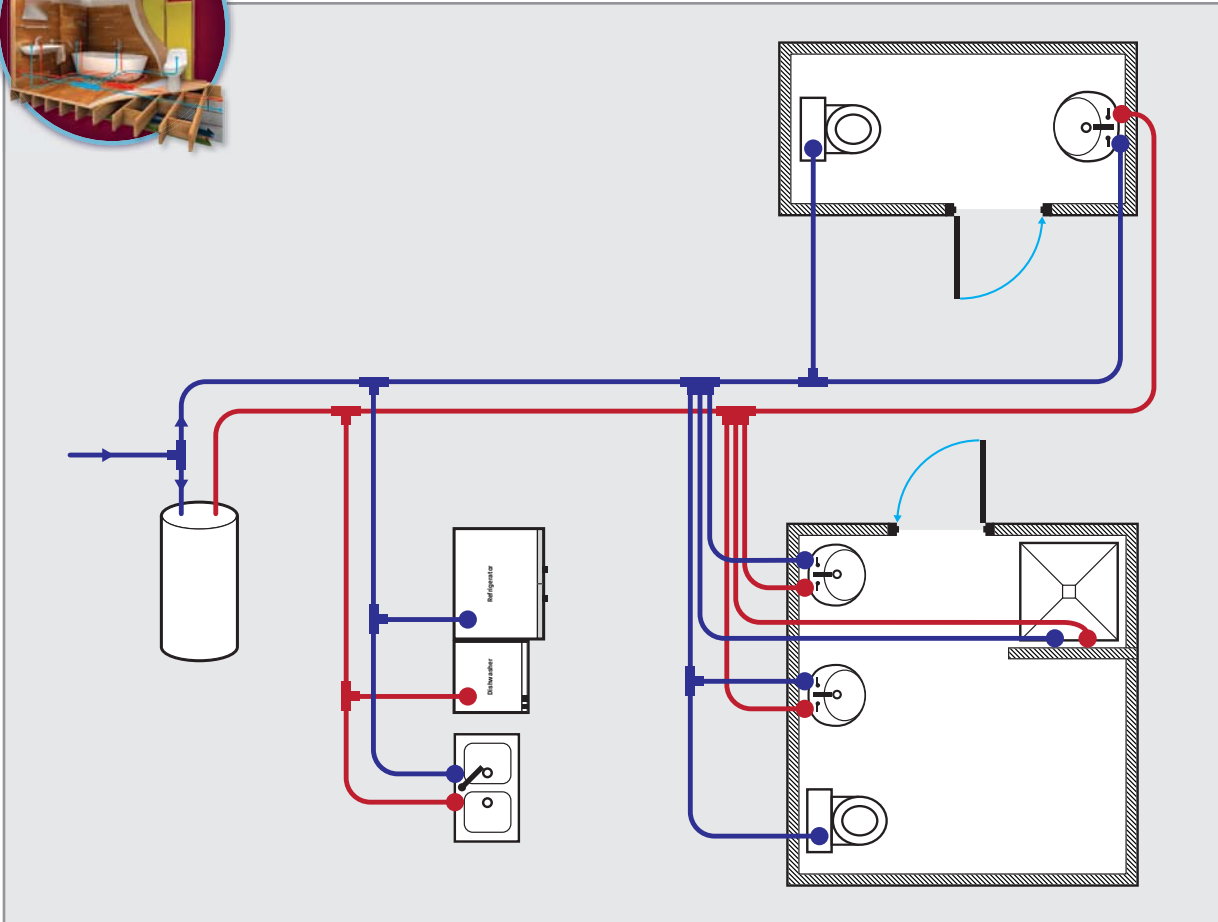

Pros: Faster installation time, less fittings and tubing. Less pressure fluctuation.

Cons: Hot water will take longer to get to furthest point.

COMBINATION METHOD WITH RECIRCULATION PUMP

This installation routes a set of main lines using multiport tee's serving a cluster of fixtures, such as a bathroom, kitchen, or laundry room. But hot side also continues back to the water heater allowing for a re-circ pump to deliver hot water quicker to the fixtures.

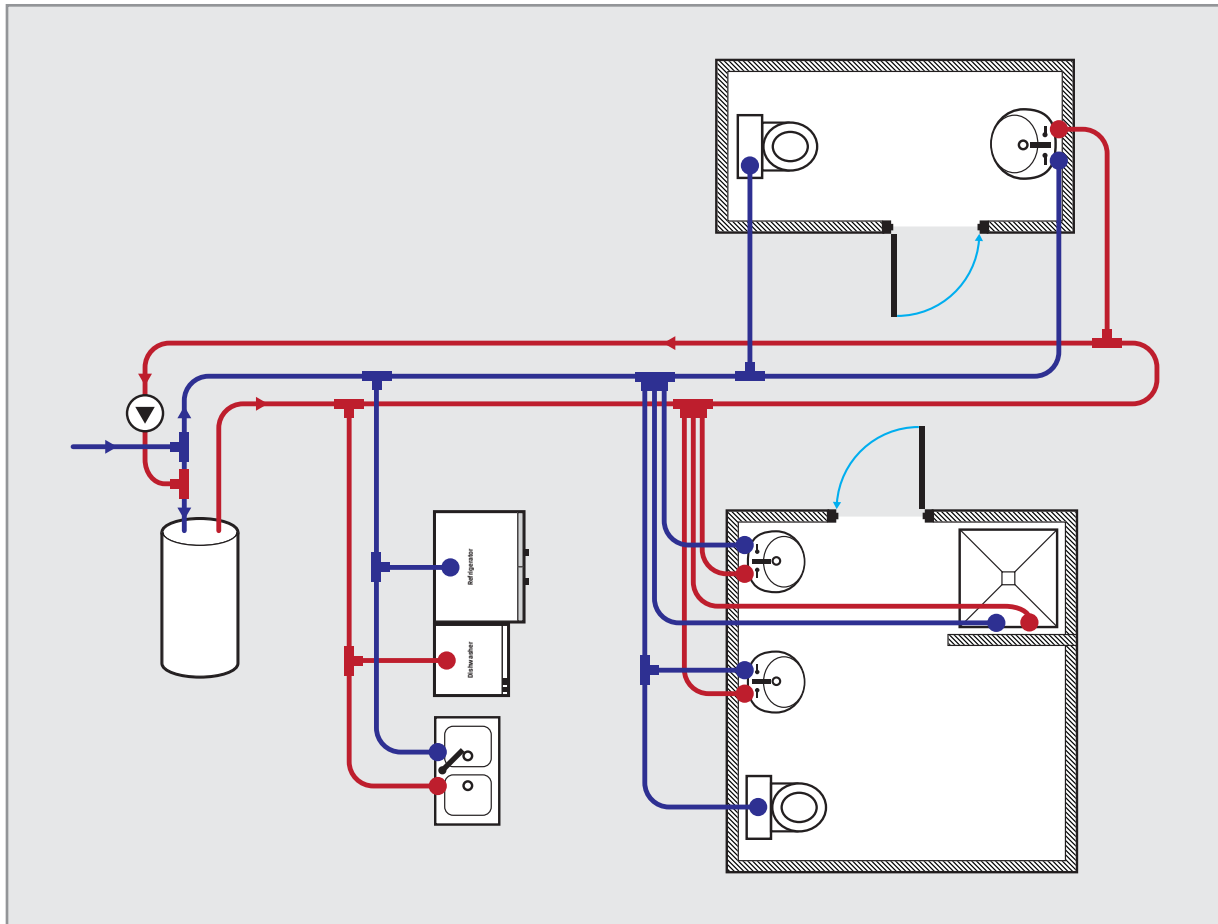

Pros: Faster installation time, less fittings and tubing. Saves on water usage. No waiting for hot water at fixture.

Cons: Installation of added hot return line.

MrPEX PEXa plumbing connections, are made using an insert fitting along with a press sleeve. This fitting meets ASTM F1807 for Lead free brass and the ASTM F2159 for PPSU plastic standards. This connection has many features such as reliability, strength, installs in seconds and is inexpensive. A tool is used to make this connection, one tool for each size is needed. MrPEX® does offer a 1/2" and 3/4" combo press tool as well as 1/2"-1" tools.