

MrPEX® 1 1/2" BRASS MANIFOLD SUBMITTAL



5300 Alpine Drive NW, Suite 210
 Ramsey, MN 55303
 support@mrpexsystems.com

Project Name _____ Date _____
 Submitted By _____ Phone _____
 Project Location _____ MrPEX® Rep. _____
 Engineer _____ Contractor _____
 Approval _____ P.O. Number _____

MrPEX® 1 1/2" Brass FOR 5/8" AND 3/4" PEX AND PEX-AL-PEX TUBING, 2-12 LOOPS

MrPEX® 1 1/2" Large Brass Manifolds are made from high-quality extruded brass and offered in 2–10 loop fully assembled manifolds. The supply body has balancing valves with adjustable flow-meters for flows up to 2 gpm per loop. The return body is equipped with on/off valves. The return balancing valve disc is designed to enable exact adjustments of small flows while still being able to handle large flow with minimal resistance. The branch Cv value is 1.3 and the manifold body accommodates flows up to 20 gpm. Manifolds are mounted on brackets ready to mount. Inlets comes with a 1 1/4" female NPT union ball valve and end caps feature vent and fill/drain. The branches have EK 25 (Eurokonus) connection.

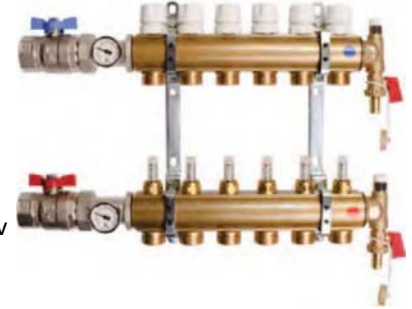

Technical Data	
Material	Brass
Working Temperature	41° F to 158°F
Max Working Pressure	87 psi
Branch Cv	1.3 Cv
Accepted media	Water, up to 50% propylene glycol
Loop Connection	EK25 (G1" Eurocone)
Available sizes	2-12 loops

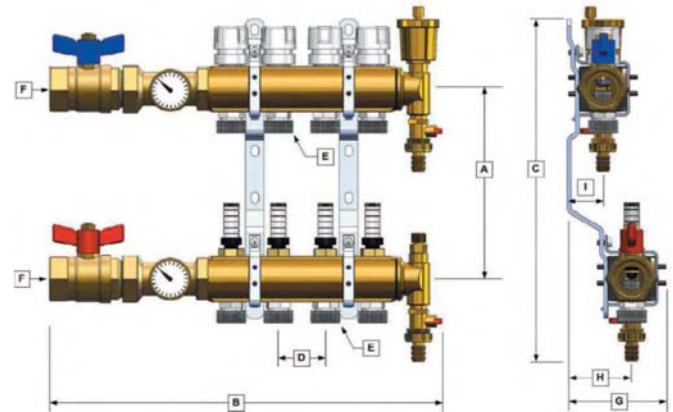

Manifold Dimensions

Part #	Type	A	B	C	D	E	F	G	H	I
3310200	2 Loop	8.25"	12.4"	13"	2"	EK25	1 1/4" FIP	4.5"	2.87	1.68"
3310300	3 Loop	8.25"	14.4"	13"	2"	EK25	1 1/4" FIP	4.5"	2.87	1.68"
3310400	4 Loop	8.25"	16.4"	13"	2"	EK25	1 1/4" FIP	4.5"	2.87	1.68"
3310500	5 Loop	8.25"	18.4"	13"	2"	EK25	1 1/4" FIP	4.5"	2.87	1.68"
3310600	6 Loop	8.25"	20.4"	13"	2"	EK25	1 1/4" FIP	4.5"	2.87	1.68"
3310700	7 Loop	8.25"	22.4"	13"	2"	EK25	1 1/4" FIP	4.5"	2.87	1.68"
3310800	8 Loop	8.25"	24.4"	13"	2"	EK25	1 1/4" FIP	4.5"	2.87	1.68"
3310900	9 Loop	8.25"	26.4"	13"	2"	EK25	1 1/4" FIP	4.5"	2.87	1.68"
3311000	10 Loop	8.25"	28.4"	13"	2"	EK25	1 1/4" FIP	4.5"	2.87	1.68"
3311100	11 Loop	8.25"	30.4"	13"	2"	EK25	1 1/4" FIP	4.5"	2.87	1.68"
3311200	12 Loop	8.25"	32.4"	13"	2"	EK25	1 1/4" FIP	4.5"	2.87	1.68"